

IMPROVEMENT AND RESTORATION OF BIOMEDICAL IMAGES BLURRED BY BODY MOVEMENT

J. Hori¹, Y. Saitoh¹, T. Kiryu², K. Okamoto³, K. Sakai³

¹Faculty of Engineering, Niigata University, Niigata, Japan

²Graduate School of Science and Technology, Niigata University, Niigata, Japan

³Department of Radiology, Niigata University School of Medicine, Niigata, Japan

Abstract - The restoration of biomedical images that have been blurred due to body movement are discussed. The observation system for these images is described using a mathematical operator and coordinate transformations. And a band-suppressed restoration filter composed of a series of such operators is proposed for improving the quality of images. In addition, redundancy is introduced into these restoration filters in order to suppress additive noise. The proposed method is applied to blurred X-ray images of a bone model of the elbow joint. The optimum position and number of markers, which are attached to the subject as a reference signal, are also discussed.

Key words - X-Ray Images, Restoration, Band-Suppression, Blur, Body Movement

I. INTRODUCTION

Recently, the progresses of medical and engineering technology bring the digitalization and the remote control of the medical information. X-ray images of the human body are often used in clinical analysis or diagnosis. However, these images are sometimes blurred due to body movement. For example, blood vessel images obtained by thoracic X-rays are often blurred due to the movement of the diaphragm in respiration. Children especially have a difficult time remaining still during an X-ray examination. Decreasing the exposure time reduces the extent of the blur, but even this does not ensure that a clear X-ray image can be obtained. The reexaminations cause the increase of the patients' radiation. Considering the remote medicine, the image data, which is generated by the reexaminations, increases the communication traffic. To overcome these problems, images must be restored to their original state. Most traditional restoration methods attempt to completely restore the original signal, which theoretically requires an infinite Nuemann series. Moreover, when the observed image is obscured by noise, the original image cannot be obtained. Several restoration filters composed of a series of fundamental filters have been proposed for biomedical signals such as blood pressure signals, electrocardiograms, and blood temperature signals [1]-[6]. These filters have successfully restored band-suppressed approximations of the signals observed in real-time using biomedical instruments. Moreover, the noise included in the observed signals is suppressed by redundant models of the filters [7]. The present authors have expanded this restoration filter to be applicable

to two spatial dimensions, and have constructed a restoration filter for blurred images [8], [9]. In the case of clinical images in radiography, the explore time is established as short as possible because of the quantity of radiation. In the present paper we suppose that the observed images are blurred by parallel or rotate translation. Thus, the band-suppressed restoration filter combined with the coordinate transformation improves the quality of the blurred images. The blurs are estimated by attaching markers, which are used as a reference signal, to the skin surface of the subject. The optimum position and the number of markers are also discussed.

II. DEFINITION OF THE PROBLEM

The problem that obtains the original X-ray image from the blurred image is interpreted as one of the inverse problems. In general, the inverse problem is defined by following equations. Let f be an original image, n be the additive noise, and A be the observation system operator. The observed image, a_0 , is defined by

$$a_0 = A f + n. \quad (1)$$

The observed image a_0 is distorted by A and n . Let B be the restoration filter, the restored image f_0 is obtained by

$$f_0 = B a_0. \quad (2)$$

In the inverse problem, f_0 in (2) must be approximately equivalent to f . Moreover, The noise in the restored image, *i.e.* Bn , must be minimized.

It is difficult to restore the completely original image f , when the noise n is present as shown in (1). We attempt to restore the band-suppressed approximation of the original image rather than the complete original image. In the present study, band-suppression refers to the gradual decay in frequency that is caused by the linear filter. Let P be the filter that causes band-suppression. A restored band-suppressed image, Pf , is then defined as

$$Pf = B a_0. \quad (3)$$

The P should be selected to cover the frequency bandwidth of the original X-ray images. The band-suppressed restoration filter can be realized by engineering techniques as shown in following section.

In the present paper, we suppose that the blurs are

caused by the parallel or rotate translation. We define the parallel translation by the L th-order observation operator,

$$A = \prod_{l=1}^L \Gamma(s_l), \quad \text{Re}\{s_l\} > 0 \quad (4)$$

where $\{s_l\}$ are any complex values.

$$\Gamma(s)f(x, y) = \frac{1}{2s} \int_{-\infty}^{\infty} e^{-\frac{|x|}{s}} f(x - \tau, y) d\tau, \quad s > 0 \quad (5)$$

where (x, y) represents the coordinates of a two-dimensional plane, and s is a parameter that represents the degree of distortion. $\Gamma(s)$ corresponds to the first-order low-pass filter having time constant s for the x -directions. The transfer functions of parallel translation for blurs along the x -axis are expressed by adjusting L and $\{s_l\}$ in (4). Moreover, not only parallel translations, but also rotations are expressed by applying coordinate transformations. In the case of rotate translation, the observation system A in (1) is replaced by

$$A' = T^{-1} A T \quad (6)$$

and the restoration filter B in (3) replaced by

$$B' = T^{-1} B T \quad (7)$$

where T is the coordinate transformation from Cartesian to polar coordinate system.

III. METHODS

As shown in section II, the restoration of blurred images is realized by combining the band-suppressed restoration filter with the coordinate transformation. In this section, we explain the details of each technique.

A. Band-Suppressed Restoration Filter

For the L th-order observation operator described in (4), we define the M ($> L$) th-order band-suppressed operator as follows:

$$P = \Gamma(s_0)^M. \quad (8)$$

We attempt to suppress the noise by introducing redundancy into the order of the restoration filter. We propose an M th-order restoration filter that restores the signals observed by the L th-order observation system. To obtain the approximation of the original image, s_0 must be set to a small value. Therefore, a restoration filter composed of $\Gamma(s_0)$ is proposed. The restoration filter for (4) is derived using

$$B = \sum_{m=0}^M b_m \{I - \Gamma(s_0)\}^m \quad (9)$$

where

$$b_m = (-1)^m \sum_{l=0}^L (-1)^l \binom{M-L}{m-l} \sum_{j=0}^l \prod_{j=1}^l \frac{s_d^2(i, j) - s_0^2}{s_0^2}. \quad (10)$$

$\binom{L}{l}$ is a binomial coefficient. The quantity $d(i, j)$ is the natural number. $I - \Gamma(s_0)$ corresponds to the high-pass filter having time constant s_0 for the x -directions. To satisfy (3), the order of the restoration filter, M , must be higher than the order of the observation system, L . Figure 1 shows a block diagram of the M th-order restoration filter for an L th-order observation system.

In order to realize the restoration filter, B , parameters such as the order M , the time constant s_0 , and the restoration coefficients $\{b_m\}$ must be determined in advance. The order M ($> L$) and the time constant s_0 ($> \text{Re}(s_l)$) can be estimated by considering the frequency bandwidth of the original image and the noise associated with the observed image. In order to determine M and s_0 , we employ an evaluation function that indicates both the precision of restoration and the amplitude of noise. At first, we consider two types of relative errors. One is the error between a band-suppressed signal and a restored signal,

$$J_1(M, s_0) = \|Pf - Ba_0\| / \|Pf\| \quad (11)$$

where J_1 expresses the amplitude of noise. The other is the error between an original signal and a restored signal,

$$J_2(M, s_0) = \|f - Ba_0\| / \|f\| \quad (12)$$

where J_2 expresses the distortion of the signal. J_1 and J_2 inversely proportional and directly proportional, respectively, to M and s_0 . Thus, we propose a new evaluation function:

$$J_3(M, s_0) = J_1(M, s_0) / J'_1 + J_2(M, s_0) / J'_2 \quad (13)$$

where J' is the average of J . J_3 represents an evaluation of both shape and noise, *i.e.*, the smaller J_3 , the better the restoration. The order M and the time constant s_0 are optimized for restoration by minimizing J_3 . We confirmed the restorative capabilities of the proposed filter using a marker. The restoration parameters $\{b_m\}$ are estimated using the response of the reference signal as the image for the a_0 that approximates the band-suppressed signal Pf . The restoration filter can be constructed using the estimated $\{b_m\}$ without actually calculating $\{s_l\}$.

B. Coordinate Transformations

The observation system in (5) represented the blur in the direction of x -axis. However, blurs in X-ray images due to body movement may occur in any direction. Moreover, not all blurs are represented by parallel translations. Here we assume that the blurs of images can be represented by Affine transformation, *i.e.*, parallel or rotation translation, because the exposure time is relatively short for X-ray examinations. We estimate the blur using a previously established marker attached to the subject as a reference signal.

In the case of rotate translation, the blurred image

caused by rotation is converted to a parallel blurred image by Cartesian-polar coordinate transformation as follows:

$$\begin{cases} r = \sqrt{(x - x_0)^2 + (y - y_0)^2} \\ \theta = \tan^{-1}\left(\frac{y - y_0}{x - x_0}\right) \end{cases} \quad (14)$$

where r and θ are the axes in polar coordinate system and (x_0, y_0) is the origin of the rotation. Replacing x and y in (5) with θ and r , respectively, the restoration filter in (9) can be applied to blurs caused by rotation translation. The linear interpolation is applied to the images for digital representation.

The blurred markers are estimated by searching the neighboring points for which the brightness was similar to the original points. We assume that the image is blurred by rotation around some point (x_0, y_0) . Assuming (x_n, y_n) , $n = 1, 2, \dots, N$, to be the original coordinates of the markers and (x'_n, y'_n) to be blurred points, the origin of the rotation (x_0, y_0) can be obtained by minimizing the following function:

$$J(x_0, y_0) = \left\| \begin{bmatrix} x'_1 - x_1 & y'_1 - y_1 \\ \vdots & \vdots \\ x'_N - x_N & y'_N - y_N \end{bmatrix} \begin{bmatrix} x_0 \\ y_0 \end{bmatrix} - \frac{1}{2} \begin{bmatrix} x_1'^2 - x_1^2 + y_1'^2 - y_1^2 \\ \vdots \\ x_N'^2 - x_N^2 + y_N'^2 - y_N^2 \end{bmatrix} \right\| \quad (15)$$

The origin (x_0, y_0) can be estimated using more than one marker. If the image is blurred in parallel translation, the origin cannot be obtained using the above method. In that case, we must estimate the direction of the translation. The blurred image at angle, ϕ , can be restored by converting the coordinates as follows:

$$\begin{pmatrix} u \\ v \end{pmatrix} = \begin{pmatrix} \cos \phi & \sin \phi \\ -\sin \phi & \cos \phi \end{pmatrix} \begin{pmatrix} x \\ y \end{pmatrix} \quad (16)$$

where u and v are converted axes in Cartesian coordinate system. Replacing x and y in (5) with u and v , respectively, the restoration filter in (9) can be applied to parallel translations in any direction. Finally, the inverse transformation of coordinates is applied to the restored image.

If there are any errors in the coordinates of markers, the origin of the rotation cannot be obtained precisely. We examined the errors between the true and estimated origin coordinates by changing the markers' location in order to analyze the influence of the coordinate errors. And the optimum number and the location of markers for restoration are obtained.

IV. SIMULATION

We estimated the precision of the coordinate transformation when the markers' location changed. In the case of two markers, the errors were minimized when the angle between two markers was right angle as shown in Fig. 2.

Fig. 3 indicates that the error decreases while the number of markers increases.

We applied the above-described method to an X-ray image of an elbow joint and confirmed the restorative capabilities of the proposed filter. We employed lead balls 3 mm in diameter, which were fixed on the body as reference signals. Using the restoration filter constructed by the reference signal, we restored an X-ray image of an elbow in Fig.4 (a). The restored image shown in Fig. 4 (c) is significantly clearer than the observed image shown in Fig. 4 (b).

The experimental results of restored images were evaluated by radiologist to determine the target of restoration. The experiments indicated that it was difficult to decide the target uniquely because of the differences of subjects, the kinds of movements, and diagnostic quality.

V. CONCLUSIONS

Toward the coming high-technology medical treatment, we researched and developed the high-fidelity improvement of medical images, which could apply for remote medicine. We proposed a filter for restoring X-ray images that have been blurred due to body movements. First, we described the observation of these images using a mathematical model. Next, we proposed the restoration filters, which restored band-suppressed approximations to their original signals. These filters were successfully applied not only in parallel translation blurs, but also blurs caused rotate translation. The parameters of the restoration filter were estimated by considering both the restorative precision and the noise. The optimum number and position of markers were also discussed in the present paper. Finally, we applied these methods to blurred X-ray images of a bone model of an elbow joint and were able to obtain clear images. We have determined that the proposed method will be useful in a broad range of practical applications after considering the automatic detection of three-dimensional movements of the subject.

ACKNOWLEDGMENT

The authors wish to thank Y. Nishimura for his experimental assistance. The present study was supported in part by a grant from the Telecommunications Advancement Organization of Japan.

REFERENCES

- [1] J. Hori, Y. Saitoh, T. Kiryu, and T. Iijima, "Automatic correction of left-ventricular pressure waveform using the natural observation method," *Trans. Inst. Elec. Inform. & Com. Eng. Jap. Info. & Syst. vol.E75-D*, pp.909-915, 1992.
- [2] J. Hori, Y. Saitoh, T. Kiryu, T. Asakawa, K. Tamura, and T. Iijima. "Improvement of frequency responses in an ambulatory ECG system by natural observation method," *Frontiers Med. & Biol. Eng. Vol.2*, pp.137-145, 1990.
- [3] J. Hori, Y. Saitoh, and T. Kiryu, "Improvement of the time-domain

response of a thermomodulation sensor by the natural observation system,” Trans. Inst. Elec. Inform. & Com. Eng. Jap. Fundamentals, vol.E77-A, pp.784-791, 1994.

- [4] J. Hori, Y. Saitoh, and T. Kiryu, “Real-time restoration of signals by the natural observation system,” Proc. 16th Int. Conf. IEEE EMBS, pp.1326-1327, 1994.
- [5] J. Hori, Y. Saitoh, and T. Kiryu, “Real-time restoration of nonstationary biomedical signals,” Proc. 2nd Int. Workshop Biosignal Interpretation, pp.119-120, 1996.
- [6] J. Hori and H. Ogawa, “Real-time restoration of nonstationary signals,” Trans. Inst. Elec. Inform. & Com. Eng. Jap., vol.J79-D-II, pp.430-438, 1996.
- [7] J. Hori, Y. Saitoh, and T. Kiryu, “Real-time restoration of biomedical signals under additive noise,” Proc. 19th Int. Conf IEEE EMBS, pp.1406-1408, 1997.
- [8] J. Hori, Y. Saitoh, and T. Kiryu, “Band-suppressed restoration of blurred X-ray images,” Proc 20th Int. Conf IEEE EMBS, pp.715-718, 1998.
- [9] J. Hori, Y. Saitoh, T. Kiryu, K. Okamoto, and K. Sakai, “Band-suppressed restoration of X-ray images blurred by body movement,” Methods Inform. Med., vol.39, pp.130-133, 2000.

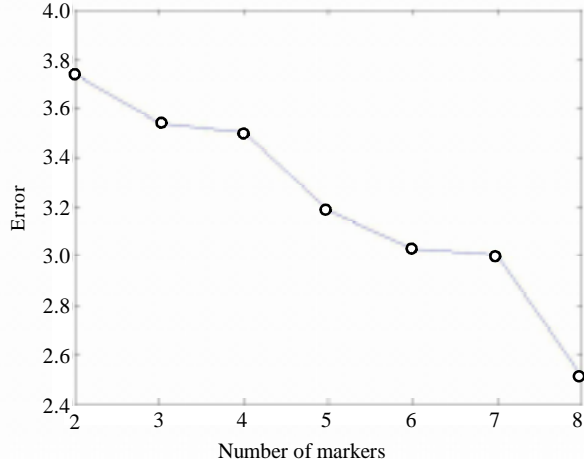

Fig. 3. Number of markers vs. estimation error in the origin coordinates.

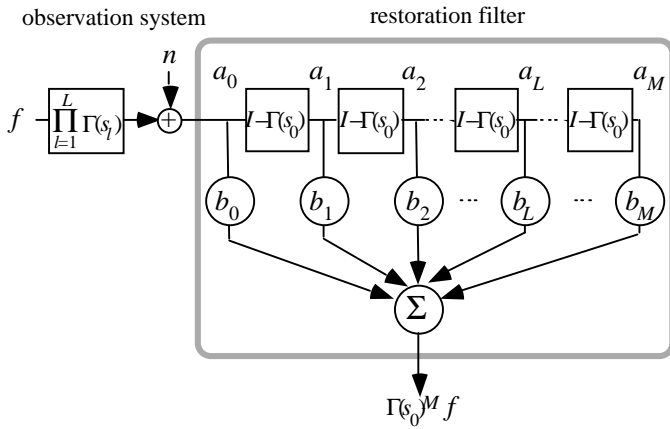

Fig. 1. M th-order restoration filter for L th-order observation system.

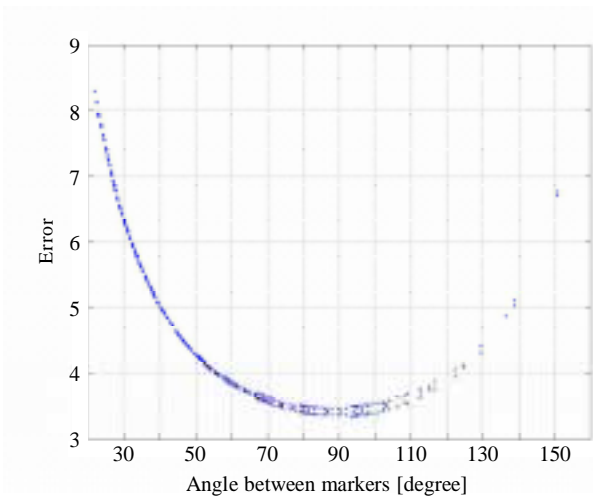
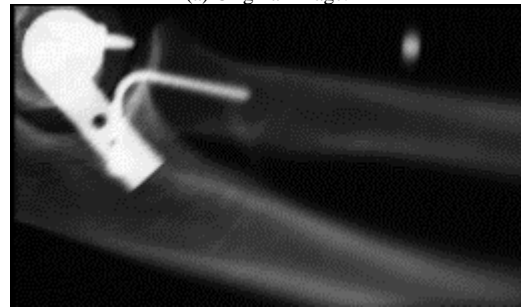

Fig. 2. Angle between markers vs. estimation error in the origin coordinates.



(a) Original image.



(b) Blurred image.

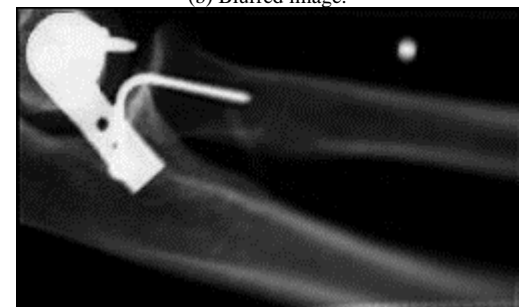

(c) Restored image.

Fig. 4. Restoration of X-ray image of an elbow joint.